

## Powered Line Array Subwoofer

### APPLICATIONS

- Permanent installations in Theatres, Concert Halls, Clubs, Discos, Houses of Worship, Conference Halls, Indoor Sports Arenas & Stadiums
- Sound Reinforcement for Live Events: Touring, Bands, Orchestras
- Any application for LF extension where uniform sound pressure level is required over the entire listening area

### FEATURES

- 3/4" Baltic birch plywood enclosure with textured scratch resistant paint finish
- 18" B&C woofer with a 4" voice coil
- 800W RMS Class "D" power amplifier
- SPL capability: 129.5dB
- Two Neutrik Powercon AC connectors (AC in, AC loop out)
- Integrated handles and mechanical hardware for flying
- Completely Manufactured in Italy



### PRODUCT DESCRIPTION

The QUBE QSA118SA is a powered compact bass reflex cabinet subwoofer. It incorporates a 18" B&C woofer with a 4" voice coil in a bass-reflex design cabinet powered by a 800W RMS Class "D" PWM Amp. With a frequency response from 35Hz-120Hz, the QSA 118 sa provides 129.5dB SPL. The control panel features a volume control, four LED indicators (pwr on, ovl, limit and protect), a ground lift switch, a balanced XLR-F input connector, a balanced XLR-M loop out connector, an auto resetting AC line circuit breaker, two Neutrik Powercon AC connectors. 2 banks of dip switches are provided for EQ presets and Delay control. The cabinet is constructed with 3/4" Baltic birch plywood and a rugged touring grade scratch resistant black paint finish protects the cabinet exterior. The system shall be flyable thanks to the user friendly built-in hardware manufactured with the highest safety standards.

### Specifications

System Type:	1-way	Low Frequency Woofer	18" / 4" Coil
Built-in Amplifier	800W RMS	Input Connectors	Balanced XLR in / thru out
Frequency Response @ -6dB	35Hz - 120Hz	Net Dimensions (WxHxD)	23.8" x 21.8" x 27.5"
Sensitivity @ 1W, 1m	98.5dB	Net Weight	128 lbs.
Maximum SPL	129.5dB	Enclosure Material	13 ply 3/4" birch plywood
Dispersion	omnidirectional		
Input Impedance	22k Ohm		

# QUBE QSA 118SA

QUBE  
World-wide distributor FBT  
www.qubeaudio.com

**FBT**  
FBT Elettronica S.p.A.  
www.fbt.it

## Powered Line Array Subwoofer

### CONTROL PANEL

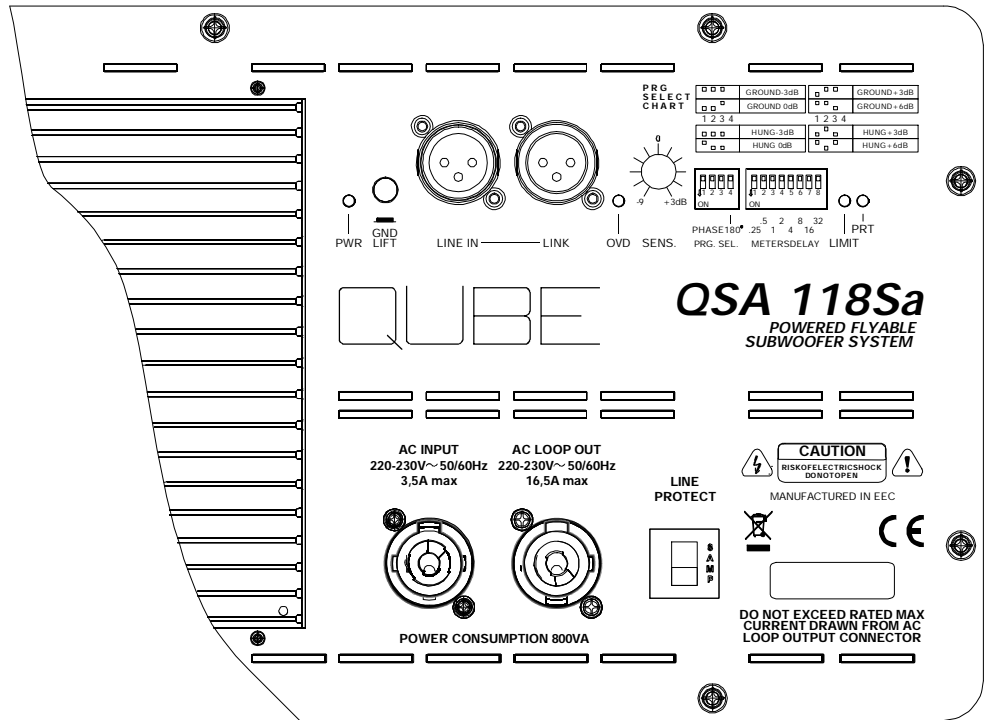

### Dimensional Drawings

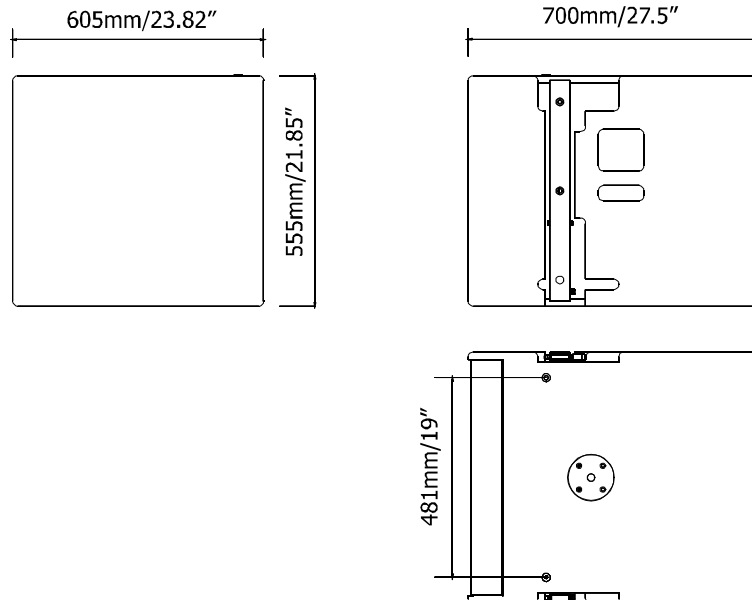

### ACCESSORIES

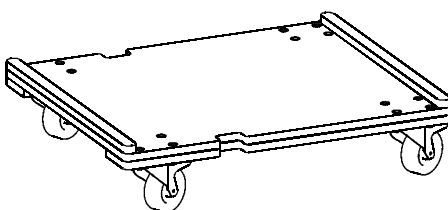

**WD-118S**  
TROLLEY WITH WHEELS TO  
TRANSPORT QSA118S/118SA

### FULL SPACE FREQUENCY RESPONSE

